

RoHS



+ Output (Tension)
- Output (Compression)

Product Description

Miniature Threaded In-Line Load Cells are strain gauge-based transducers with temperature compensation and excellent overall performance. This type measures tensile and compressive loads up to 50kN and 10klbf with better than $\pm 0.5\%$ non-linearity.

Performance Specifications

Parameter	Range	Notes
Capacity	10kN, 20kN & 50kN	With metric threads as standard
	3klbf, 5klbf & 10klbf	With unified threads as standard
Rated Output (RO)	2mV/V nom.	
Allowable maximum load	150% full scale	No effect on performance
Non-linearity	$\pm 0.5\%$ of RO MAX	
Hysteresis	$\pm 0.5\%$ of RO MAX	
Repeatability	$\pm 0.1\%$ of RO MAX	
Zero balance	5% of RO MAX	
Zero temp coefficient	0.02% FS / °C	
Span temp coefficient	0.02% load / °C	
Compensated temp range	-15 °C TO 70 °C	Wider range available to order
Operating temp range	-20 °C TO 80 °C	Wider range available to order
IP Rating	IP64	
Bridge resistance	350 ohm nom.	
Excitation	5v Recommended, 10v Max	

Wiring

- The load button is provided with 4x28 AWG wiring within a braided shielded cable (overall cable length 3m).
- Connector with integrated TEDS chip is available to order.

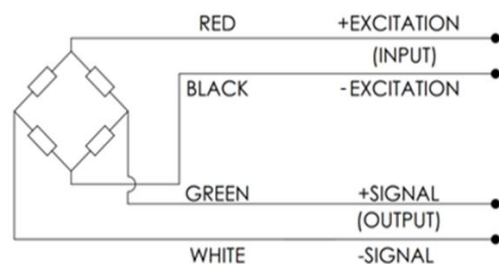

Dimensions mm [inch]

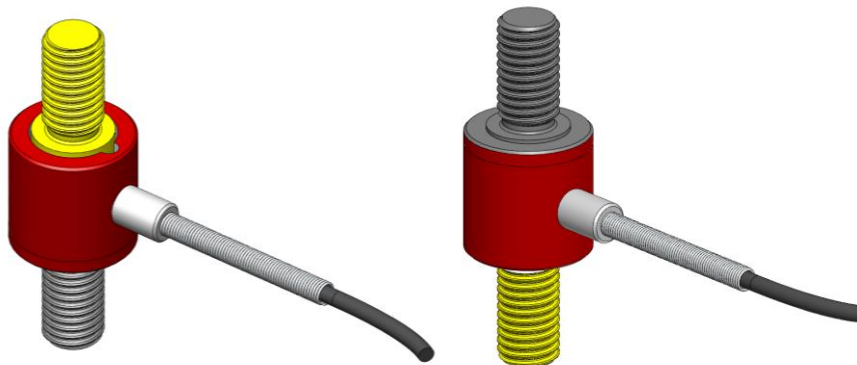
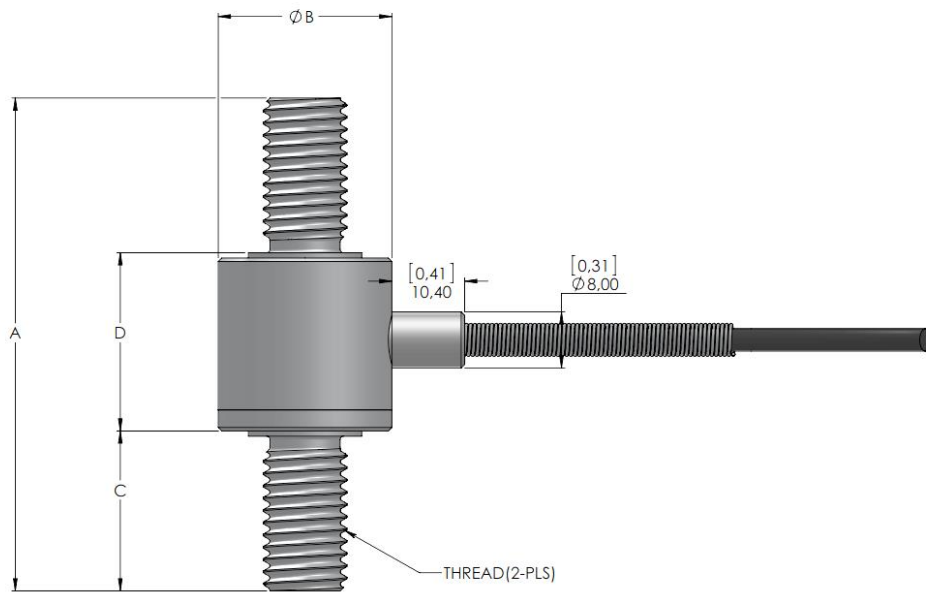

	Non loading surface
	Active End
	Fixed End

Model	Capacity	A	B	C	D	Thread
106-10	10kN	38.10mm[1.50"]	24.80mm[.98"]	10.65m[.42"]	17.55mm[.69"]	M10x1.5-6g
	3klbf	38.10mm[1.50"]	24.80mm[.98"]	10.65m[.42"]	17.55mm[.69"]	3/8"-24 UNF 2B
107-10	20kN	70.40mm[2.77"]	24.80mm[.98"]	22.85mm[.90"]	25.45mm[1.00"]	M12x1.75-6g
	5klbf	70.40mm[2.77"]	24.80mm[.98"]	22.85mm[.90"]	25.45mm[1.00"]	1/2"-20 UNF 2B
108-10	50kN	70.40mm[2.77"]	28.30mm[1.11"]	22.10mm[.87"]	26.20mm[1.03"]	M16X2.0-6g
	10klbf	70.40mm[2.77"]	28.30mm[1.11"]	22.10mm[.87"]	26.20mm[1.03"]	3/4"-16 UNF 2B

Model	Capacity	Deflection Nom.
106-10	10kN	0.04mm[.0015"]
	3klbf	0.04mm[.0015"]
107-10	20kN	0.04mm[.0015"]
	5klbf	0.04mm[.0015"]
108-10	50kN	0.08mm[.003"]
	10klbf	0.08mm[.003"]