

Product Description

The HTSB Load Cell is a bi-directional Aluminum strain gauge-based transducer with high performance, specially designed for high temperature applications. This design provides better than $\pm 0.05\%$ (full scale) non-linearity.

Performance Specifications

▪ RATED CAPACITY	50, 100, 150 & 250 lbf
▪ RATED OUTPUT (RO)	3mV/V nom.
▪ SAFE OVERLOAD	150 % of R.O.
▪ NO LOAD OFFSET (ZERO BALANCE)	$\pm 1\%$ of R.O.
▪ EXCITATION (VDC OR VAC)	10 MAX, 5V recommended
▪ INPUT IMPEDANCE	350 Ω nom.
▪ OUTPUT IMPEDANCE	350 Ω nom.
▪ NON-LINEARITY	$\pm 0.05\%$ of R.O.
▪ HYSTERESIS	$\pm 0.03\%$ of R.O.
▪ NONREPEATABILITY	$\pm 0.02\%$ of R.O.
▪ TEMP. SHIFT ZERO	$\pm 0.005\%$ of R.O./ $^{\circ}\text{F}$ (± 0.009 of R.O./ $^{\circ}\text{C}$)
▪ TEMP. SHIFT SPAN	$\pm 0.005\%$ of LOAD/ $^{\circ}\text{F}$ (± 0.009 of LOAD/ $^{\circ}\text{C}$)
▪ COMPENSATED TEMP.	0 to 300 $^{\circ}\text{F}$ (-20 to 150 $^{\circ}\text{C}$)
▪ OPERATING TEMP	-65 to 320 $^{\circ}\text{F}$ (-54 to 160 $^{\circ}\text{C}$)
▪ MATERIAL	Aluminum
▪ CALIBRATION (STD)	Tension

Wiring

- The HTSB load cell is provided with 4x22 AWG wiring within a braided shielded cable (overall cable length 15ft)

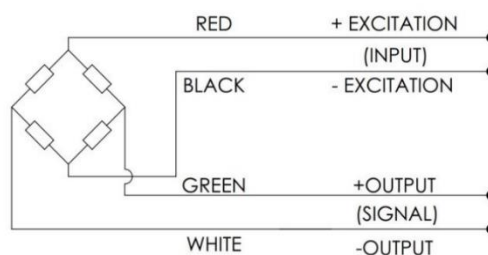

Dimensions (mm)

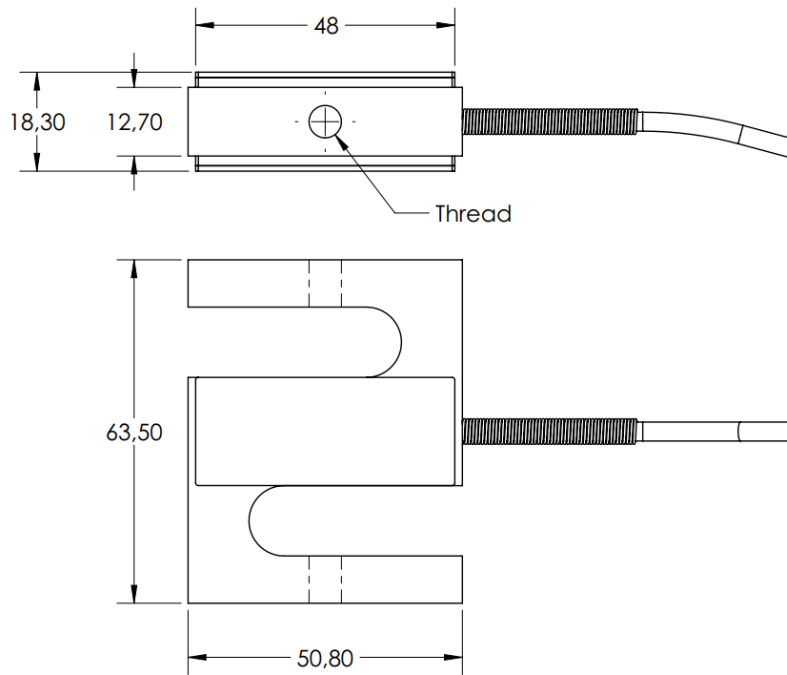

Model	Capacity (lbf)	Thread
HTSB-M	50	M6 x 1
HTSB-U	50	1/4 - 28
HTSB-M	100	M6 x 1
HTSB-U	100	1/4 - 28
HTSB-M	150	M6 x 1
HTSB-U	150	1/4 - 28
HTSB-M	250	M6 x 1
HTSB-U	250	1/4 - 28